

EXPERIMENT -8

OIL POWER HYDRAULIC SYSTEM

AIM: To study the components of oil power hydraulic system and its working.

THEORY:

1.Fluid power:

- Fluid power is the method of using pressurized fluid to transmit energy.
- Liquid or Gas is referred to as a fluid. Accordingly, there are two branches of fluid power; Pneumatics, and Hydraulics.
- Hydraulic systems use liquid to transfer force from one point to another.
- Pneumatic systems use air to transfer force from one point to another.

Fluid power is the technology that deals with the generation, control and transmission of forces and movement of mechanical element or system with the use of pressurized fluids in a confined system.

2.Basic Components of a Hydraulic System

Hydraulic systems are power-transmitting assemblies employing pressurized liquid as a fluid for transmitting energy from an energy-generating source to an energy-using point to accomplish useful work. Figure 1 shows a simple circuit of a hydraulic system with basic components

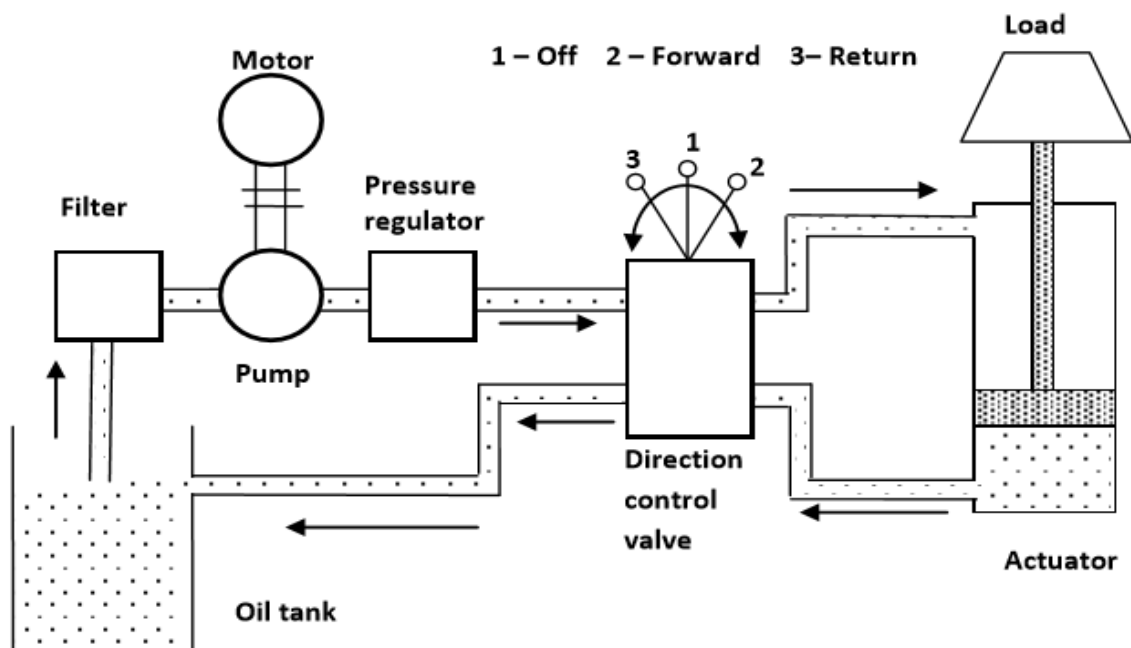

Figure 1. Components of a hydraulic system

Functions of the components shown in Fig. 1 are as follows:

1. The hydraulic actuator is a device used to convert the fluid power into mechanical power to do useful work. The actuator may be of the linear type (e.g., hydraulic cylinder) or rotary type (e.g., hydraulic motor) to provide linear or rotary motion, respectively.
2. The hydraulic pump is used to force the fluid from the reservoir to rest of the hydraulic circuit by converting mechanical energy into hydraulic energy.
3. Valves are used to control the direction, pressure and flow rate of a fluid flowing through the circuit.
4. External power supply (motor) is required to drive the pump.
5. Reservoir is used to hold the hydraulic liquid, usually hydraulic oil.
6. Piping system carries the hydraulic oil from one place to another.
7. Filters are used to remove any foreign particles so as keep the fluid system clean and efficient, as well as avoid damage to the actuator and valves.
8. Pressure regulator regulates (i.e., maintains) the required level of pressure in the hydraulic fluid.

The piping shown in Fig. 1 is of closed-loop type with fluid transferred from the storage tank to one side of the piston and returned back from the other side of the piston to the tank. Fluid is drawn from the tank by a pump that produces fluid flow at the required level of pressure. If the fluid pressure exceeds the required level, then the excess fluid returns back to the reservoir and remains there until the pressure acquires the required level.

Cylinder movement is controlled by a three-position change over a control valve.

- a. When the piston of the valve is changed to upper position, the pipe pressure line is connected to port A and thus the load is raised.
- b. When the position of the valve is changed to lower position, the pipe pressure line is connected to port B and thus the load is lowered.
- c. When the valve is at center position, it locks the fluid into the cylinder (thereby holding it in position) and dead-ends the fluid line (causing all the pump output fluid to return to tank via the pressure relief).

3.Properties of Hydraulic oils

a)Compressibility:

Liquids are incompressible in nature hence they are suitable for precise motion control. Hydraulic oil should have low compressibility for better performance.

b)Viscosity:

Oils with low viscosity flow easily but thick. Oil flows with some difficulty and result in pressure loss in the pipes and fittings. The low viscosity oil do not lubricate very well hence the right balance between pressure loss and lubricity is required while selecting oil viscosity.

c)Demulsibility :

The ability of oil to resist with mixing with water is known as Demulsibility.

d)Low foaming tendency:

A good hydraulic fluid will not absorb air easily and will release it quickly without causing foam.

e)Oxidation:

Oxidation causes the oil to thicken and produces varnishes which strain the component surface. It reduces life of oil. Chemicals may be added to improve oxidation of oil.

f)Good heat dissipation:

The oil should carry out the heat generated and dissipate to the atmosphere easily and at faster rate.

g)Wear resistant (good lubricity) :

Chemicals are added to improve wear resistance of oil for reduction of wear during contact with moving components.

h)Corrosion resistance:

The oil should have high corrosion resistance to eliminate the problems related to corrosion.

i)Pour points :

It is important during low temperature application in cold climates. The oil should have low pour point temperature.

j)Flash point:

It is the temperature at which vapor of oil given off when in contact with flame. It is required for high temperature application.

k)Non-toxic , easy to handle and easily available:

Hydraulic oil should be nontoxic for safe use and handling. It should be easily available at economic price.

4.Advantages of Hydraulic system

- Large load capacity with almost high accuracy and precision.
- Smooth movement.
- Automatic lubricating provision to reduce to wear.
- Division and distribution of hydraulic force are easily performed.
- Limiting and balancing of hydraulic forces are easily performed.

5.Disadvantages of Hydraulic system

- A hydraulic element needs to be machined to a high degree of precision.
- Leakage of hydraulic oil poses a problem to hydraulic operators.
- Special treatment is needed to protect them from rust, corrosion, dirt etc.,
- Hydraulic oil may pose problems if it disintegrates due to aging and chemical deterioration.
- Hydraulic oils are messy and almost highly flammable.

6.Applications:

The following are the some of the applications of oil power hydraulic system

- Automobile power steering
- Brakes
- Aircraft landing gear
- Lift trucks
- Front end loaders.

RESULT: The required properties of oil and components of oil power hydraulic system are studied.

EXPERIMENT -9

PNEUMATIC SYSTEM

AIM: To study the components of Pneumatic system and its working.

THEORY:

1.Fluid power:

- Fluid power is the method of using pressurized fluid to transmit energy.
- Liquid or Gas is referred to as a fluid. Accordingly, there are two branches of fluid power; Pneumatics, and Hydraulics.
- Hydraulic systems use liquid to transfer force from one point to another.
- Pneumatic systems use air to transfer force from one point to another.

Fluid power is the technology that deals with the generation, control and transmission of forces and movement of mechanical element or system with the use of pressurized fluids in a confined system.

2.Basic Components of a Pneumatic System

A pneumatic system carries power by employing compressed gas, generally air, as a fluid for transmitting energy from an energy-generating source to an energy-using point to accomplish useful work. Figure 2 shows a simple circuit of a pneumatic system with basic components.

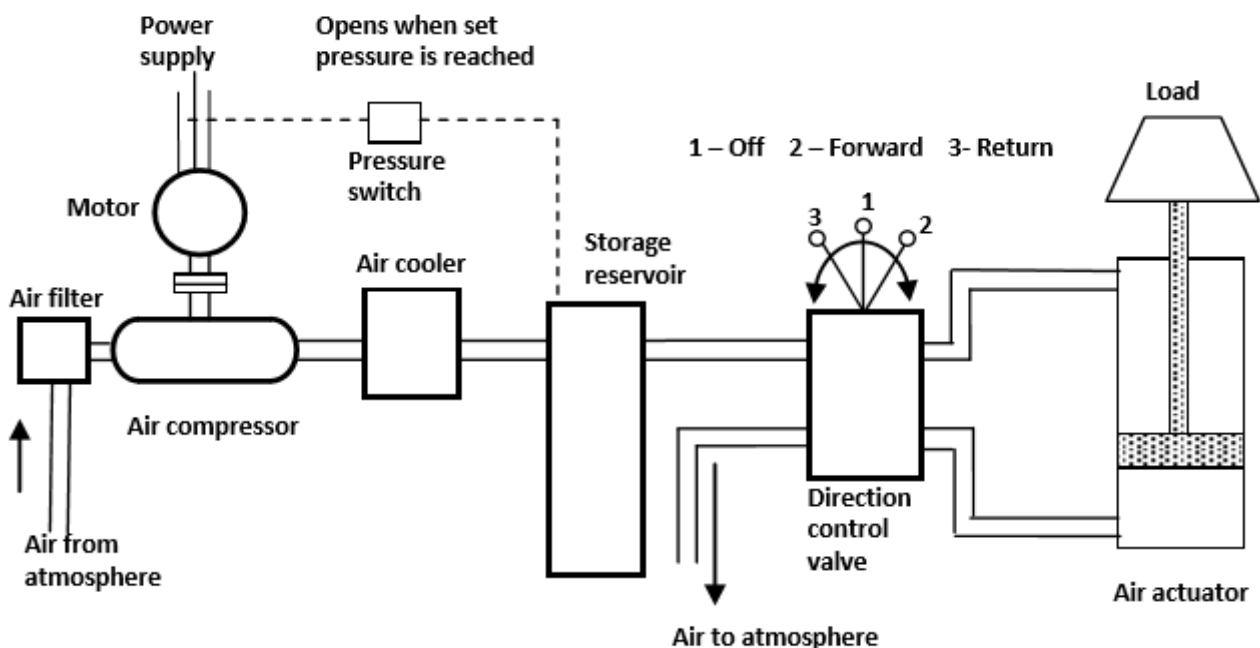

Figure 2. Components of a pneumatic system.

The functions of various components shown in Fig. 2 are as follows:

1. The pneumatic actuator converts the fluid power into mechanical power to perform useful work.
2. The compressor is used to compress the fresh air drawn from the atmosphere.
3. The storage reservoir is used to store a given volume of compressed air.
4. The valves are used to control the direction, flow rate and pressure of compressed air.
5. External power supply (motor) is used to drive the compressor.
6. The piping system carries the pressurized air from one location to another.

Air is drawn from the atmosphere through an air filter and raised to required pressure by an air compressor. As the pressure rises, the temperature also rises; hence, an air cooler is provided to cool the air with some preliminary treatment to remove the moisture. The treated pressurized air then needs to get stored to maintain the pressure. With the storage reservoir, a pressure switch is fitted to start and stop the electric motor when pressure falls and reaches the required level, respectively.

The three-position change over the valve delivering air to the cylinder operates in a way similar to its hydraulic circuit.

3.Advantages:

- One of the reasons why a pneumatic system is commonly used in industrial equipment is that it is intrinsically safe. It does not derive power or energy from electricity
- Atmospheric air is abundant and readily available, which makes the power source an infinite resource.
- A pneumatic system purges compressed air, automatically keeping the instrument clean and free from contaminants that can damage or prevent the system from working.
- A pneumatic system is easy to maintain and easy to use.
- Pneumatic systems are suitable for working environments exposed to radiation and high temperature, which makes pneumatics immune to most elements present in nature.

4.Disadvantages:

- A pneumatic device is sensitive to extreme changes in temperature as well as vibration.

- Compressed air is more expensive than electricity
- It is essential to ensure that there are no leaks in a pneumatic system because compressed air escaping leads to energy loss.
- Pneumatic systems are known for making a loud noise. As a solution, you can install a silencer in every dump line.
- Installation cost increases when the instrument requires speciality pipes.
- Pneumatic systems are not upgradable to become compatible with smart electronics.

5.Applications:

Pneumatic equipment’s can be used for applications, where operation cycles need certain routine functions like

- Pushing
- Pulling
- Lifting
- Feeding
- Clamping
- Pressing
- Forming

6.Comparison between Hydraulic and Pneumatic Systems

S.No.	Hydraulic System	Pneumatic System
1.	It employs a pressurized liquid as a fluid	It employs a compressed gas, usually air, as a fluid
2.	An oil hydraulic system operates at pressures up to 700 bar	A pneumatic system usually operates at 5–10 bar
3.	Generally designed as closed system	Usually designed as open system
4.	The system slows down when leakage occurs	Leakage does not affect the system much
5.	Valve operations are difficult	Valve operations are easy
6.	Heavier in weight	Lighter in weight
7.	Pumps are used to provide pressurized liquids	Pumps are used to provide compressed gases
8.	The system is unsafe to fire hazards	The system is free from fire hazards
9.	Automatic lubrication is provided	Special arrangements for lubrication are needed

Table 1. comparison between hydraulic and pneumatic systems

RESULT: The components of the pneumatic power system are studied.